



# ACCESS DOORS



**Model 20-HAD**

### STANDARD CONSTRUCTION

**FRAME:** 22 GA. GALV. STEEL  
**DOOR PANEL:** 26 GA. GALV. STEEL  
**FINISH:** GALV. STEEL

1" THICK HINGED ACCESS DOOR WITH FLANGE  
 FRAME 22 GA. GALV. STEEL  
 1" OUTBOARD FLANGE ALL(4) SIDES  
 1/8" X 1-1/2" PRESSURE SENSITIVE FOAM TAPE (4) SIDES  
 1/8" X 1/2" INSIDE DOOR SEAL

### OPTIONS:

Finish: Aluminum, powder coat or stainless steel

**MODEL:**  
**20-HAD**  
**25-CAD**

Standard models are 1" thick hinged or double cam lock insulated doors.

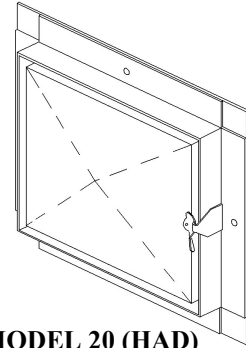

**MODEL 20 (HAD)**  
Hinged 1" access door with insulation

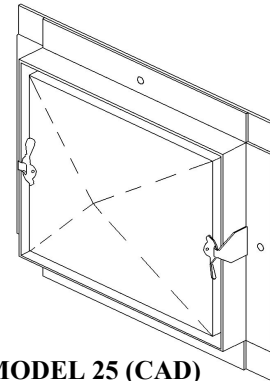

**MODEL 25 (CAD)**  
Double cam 1" access door with insulation

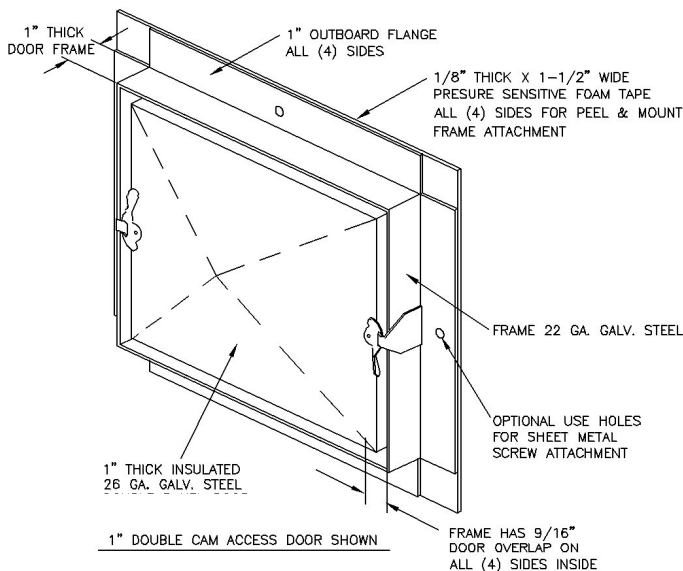

### NOTE:

- Hinged doors over 14" x 14" have 3 cam latches. Double cam doors over 14" x 14" have 4 cam latches.
- All models include 1/8" thick x 1/2" wide door-to-frame gasket.

