



COMBINATION FIRE SMOKE DAMPER



MODELS:
FSD-111-3-PB

APPLICATION

The FSD-111-3PB is a Lloyd's class 3 leakage, 1-1/2 HR combination fire & smoke damper with 3 "V" blades. The FSD-111-3PB can be installed vertically or horizontally in HVAC systems and is rated for airflow and leakage in either direction. The FSD-111-3PB has been qualified with velocities to 2000 fpm and pressures to 4.0 in. w.g.

STANDARD CONSTRUCTION

- FRAME:** 16 ga. (1.5mm) Galvanized steel
Interlocking stacked hat section
Channel frame construction
- BLADES :** 16 ga. Galvanized 3 "V" formed
Parallel blade
- BEARINGS:** Sintered Bronze, oil impregnated
- AXLES:** 1/2 Sq. zinc plated steel studs
- LINKAGE:** 0.12x0.50 zinc plated steel
concealed in the channel frame
- FINISH:** Mill galvanized
- BLADE SEALS:** 60-65 Durometer silicone rubber
with laminated acrylic adhesive
permanently bonded to blade edges.
- JAMB SEALS:** Corrosion resistant stainless steel
- JACKSHAFT:** 1/2" Dia. Zinc plated steel with
jackshaft connector coupling
- CAULKING:** UL Approved silicone sealants:
Dow corning RTV-732, 999A,
GE-1200
- SLEEVE:** Specify: Rectangle, round, oval or
special

RATINGS

- Fire rating: 1-1/2 Hours
- Leakage: Class 3
- Installations: Vertical/ Horizontal
- Maximum velocity: 2000fpm
- Maximum static pressure: 4.0" W.G.
- Temperature rating: 250° F/350° F
- Operation rating: Power open/ Spring closure

UL CLASSIFIED: UL 555 & UL 555S

Model FSD-111-3-PB meets the requirements for fire dampers, smoke dampers and combination fire smoke dampers established by:

- CSFM California State Fire Marshal
Fire Damper Listing (#3225-1417:102)
Leakage (Smoke) Damper Listing (#3230-1417:103)
New York City (MEA listing #215-99-E)
British Standard (BS – 476 Part 20)
Performance testing by AMCA International
(AMCA STD 500)
HKFM Hong Kong fire Marshal Approval**



OPTIONAL MATERIAL:

Stainless steel construction

ACTUATOR:

- Specify type: Electric or Pneumatic
- Specify brand: SIEMENS, BELIMO
- Specify mounting: External or internal
- Specify voltage: 24V, 120V, 220V

Single Section		Multiple Section
Minimum Size (WxH)	Maximum Size (WxH)	Maximum Size (WxH)
8"x8"	36"x36"	72"x72"
	30"x48"	

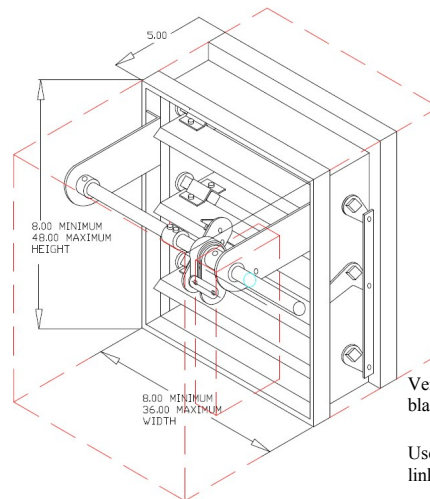

Vertical mount parallel blade damper shown

Used with fusible links 165°F

