



CEILING RADIATION DAMPER

MODELS:
50 (Rectangular)



APPLICATION

The CRD-50 has been UL tested and labeled for protection of ceiling openings in fire rated floor/ceiling assemblies with fire resistance ratings of 3 hours or less. This product can also be applied to steel lay-in style ceiling diffusers up to 24 in. x 24 in. (610mm x 610mm) maximum size. The unit is UL fire rated Ceiling/Floor Assembly L-563 and Ceiling/Roof Assembly P-544.

RATING:

UL CLASSIFIED: UL 555C Fire Resistance Rating
Fire resistance rated 3 Hours
Building materials rated 3 Hours or less

Standard Construction

1. UL listed link (165°F Standard)
2. Blades 22 (0.853mm) Ga. Galv. Steel
3. Roll-formed frame 22 (0.853mm) ga. Galv. Steel
4. Steel duct drop (by others).

Model CRD 50 meets the requirements for fire dampers established by:

**CSFM California State Fire Marshal
Fire Damper Listing (#3225-1417:101)**



Note:

1. Maximum size 24"x24" (600mm x 600mm)
Minimum size 4"x4" (101mm x 101mm)
2. Available in stainless steel
3. Manufactured with blade opening as per sketch #1: when "W" equal to or greater than 6"
4. Manufactured with blade opening as per sketch #2: when "W" is less than 6" and "H" is greater than "W".
5. "Ceramic insulation is not UL required on dampers with areas less than 80 square inches of blade surface. Dampers above 80 square inches will be provided with blade insulation.

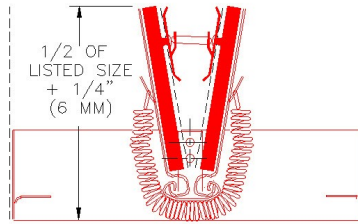

CRD SHOWN IN OPEN POSITION

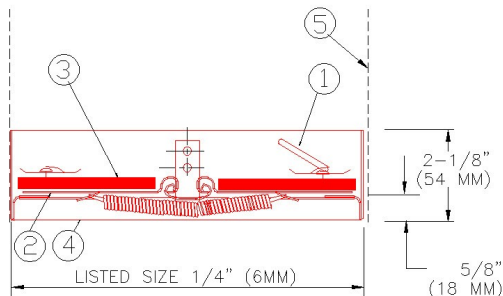

CRD SHOWN IN CLOSED POSITION

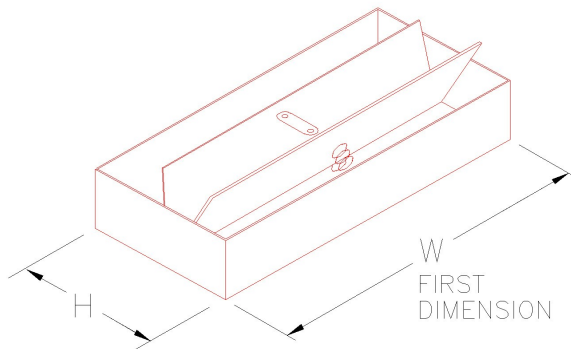

SKETCH 1

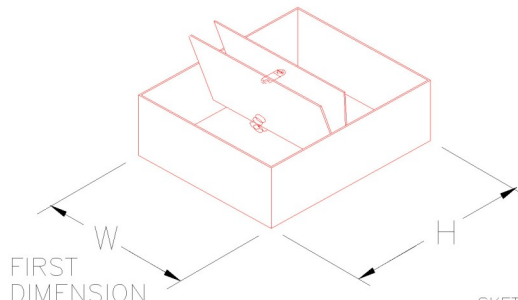

SKETCH 2

Note:
First dimension is always the hinge length
Example:
A 12x6 CRD 50-EA has a 12"(W) long hinged length