



CEILING RADIATION DAMPER WITH REGISTER BOX ASSEMBLY

MODEL:
CRD50-NI-BT-26GT
CRD50-NI-BT-26GT-EA



APPLICATION

Model CRD50-NI-BT-26GT/ CRD50-NI-BT-26GT-EA is an 1-Hour rated CRD/ Register/Grille assembly.

TYPE CRD: Rectangular damper with non-insulated register box, "top outlet".

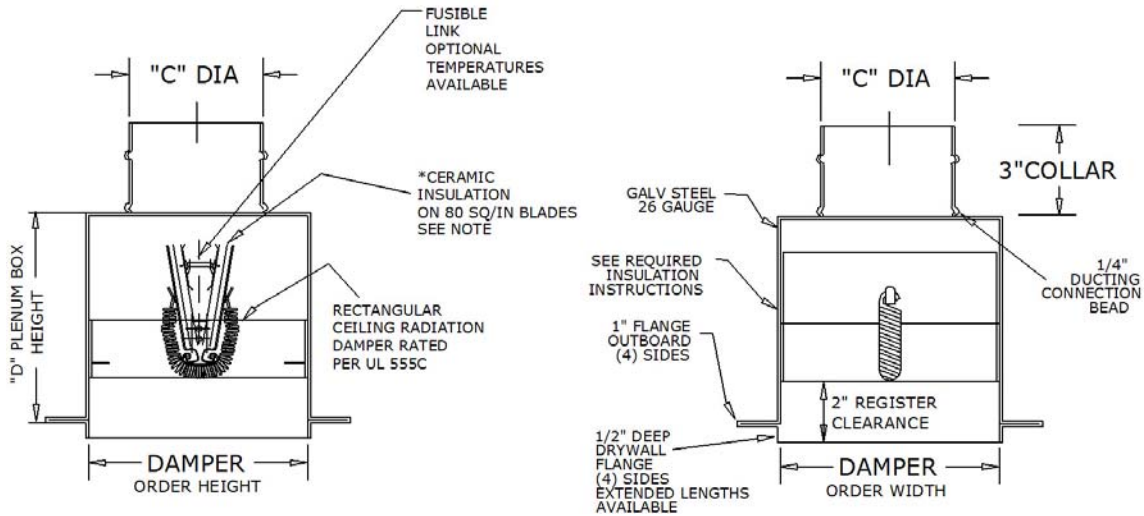

CEILING RADIATION DAMPER

- Rating: UL listed ceiling radiation damper UL-555C
- Fusible Link: 165°F standard
- Blades: 22 Ga. Galv. Steel with ceramic fiberglass cover
- Frame: Roll formed 22 Ga. Galv. Steel

PLENUM BOX

- Outer Box: 26 Ga. Galv. Steel
- Collar: Roll formed 26 Ga. Galv. Steel with roll formed 1/4" beading
- Insulation: None provided
- "C" Diameter provided nominal order diameter

NOTES:

- Available in stainless steel.
- Manufactured with blades open as shown. (Except when register width "W" is less than 6")
- Minimum CRD50-EA-NI-BT register sizes not less than 6" on width and 6" on height.
- Ceramic insulation is not required on dampers with areas less than 80 SQ/IN and is optional. Dampers above 80 SQ/IN will be provided with blade insulation.
- Register/Grille supplied by other.

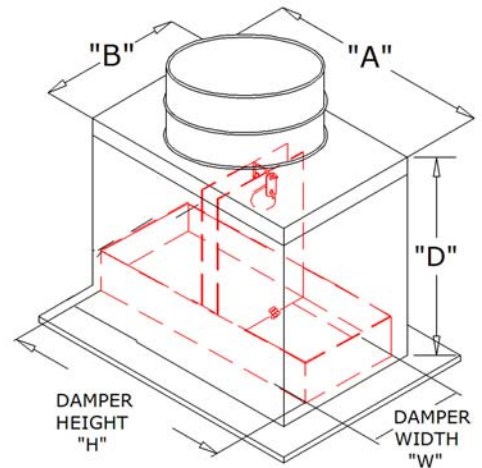

Minimum Size (WxH)	Maximum Size (WxH)
6"x6"x3" (collar)	24"x24"x22" (collar)