



**CEILING RADIATION DAMPER WITH REGISTER BOX ASSEMBLY**

**MODEL:**  
**CRD55-BT-4.2-45**  
**CRD55-EA-BT-4.2-45**



**APPLICATION**

Model CRD55-BT-4.2-45 / CRD55-EA-BT-4.2-45 is an 1-Hour rated CRD/ Register/Grille assembly. 45° CRD/Register box is acceptable for both floor/ ceiling and roof ceiling assemblies include L546, L521 and P522 by ARL tested.

**TYPE CRD: "ROUND"**

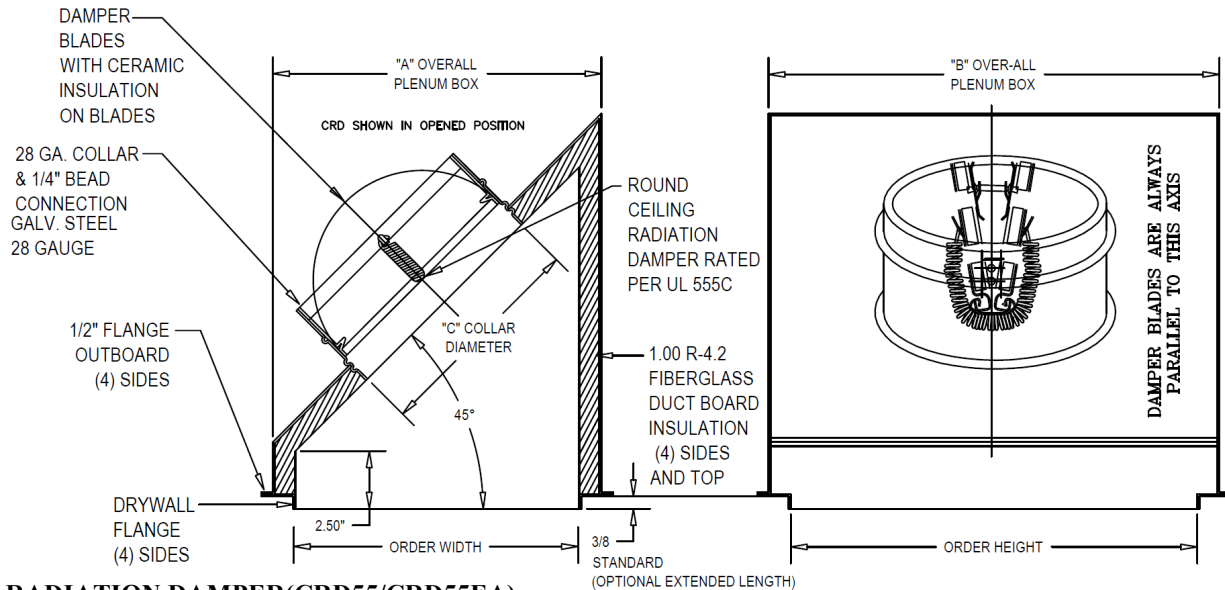

**CEILING RADIATION DAMPER(CRD55/CRD55EA)**

- Fusible Link: 165°F standard (options are available )
- Blades: 22 Ga. Galv. Steel with ceramic fiberglass cover
- Frame: Roll formed 22 Ga. Galv. Steel

**PLENUM BOX**

- Outer Box: 28 Ga. Galv. Steel
- Collar: Roll formed 28 Ga. Galv. Steel with roll formed 1/4" beading
- Insulation: Fiberglass duct board 1" thick (R-4.2)
- "C" Diameter provided nominal order diameter

**NOTES:**

- Available in stainless steel.
- Available with extended length drywall flange.
- Collar Diameter: Minimum 3", Maximum 12".
- Register/Grill (steel) supplied by other.
- Ceramic insulation is not required on dampers with areas less than 80 SQ/IN and is optional. Dampers above 80 SQ/IN will be provided with blade insulation.
- **Meets NFPA 90A requirements.**

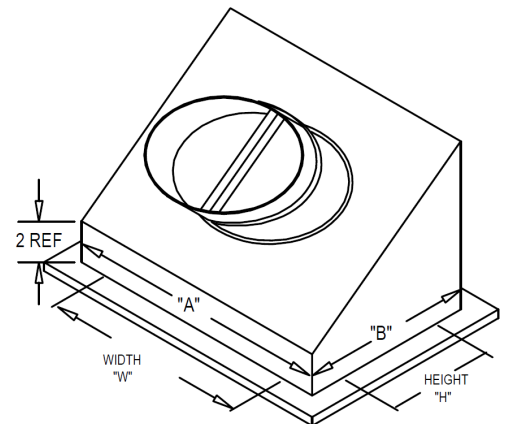

Minimum Size (WxH)	Maximum Size (WxH)
6"x6"x4" (collar)	16"x16"x12" (collar)