

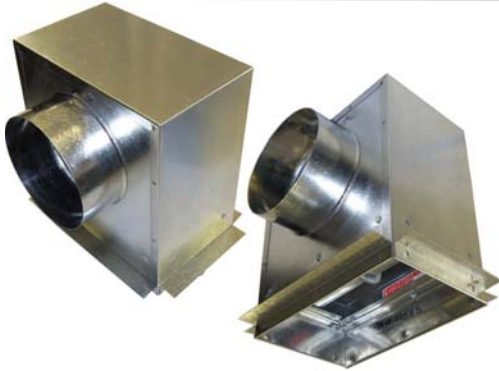

CEILING RADIATION DAMPER WITH REGISTER BOX ASSEMBLY

MODEL:
CRD50-NI-BT-26GS
CRD50-NI-BT-26GS-EA



APPLICATION

Model CRD50-NI-BT-26GS/ CRD50-NI-BT-26GS-EA is an 1-Hour rated damper and box assembly.

TYPE CRD: Rectangular damper with non-insulated Galv. Steel register box and side outlet, type "CR" round collar.

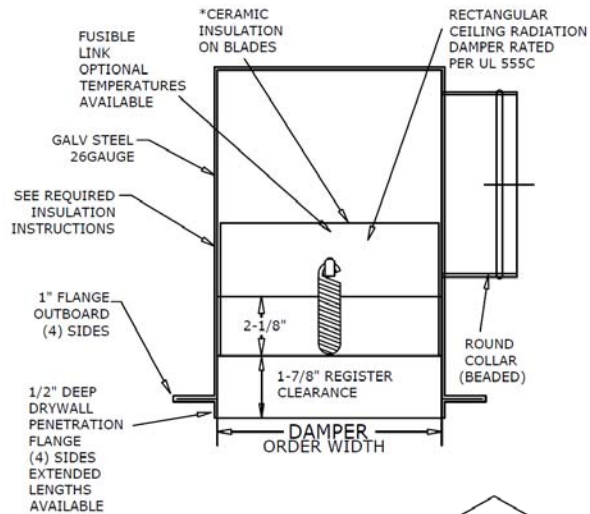
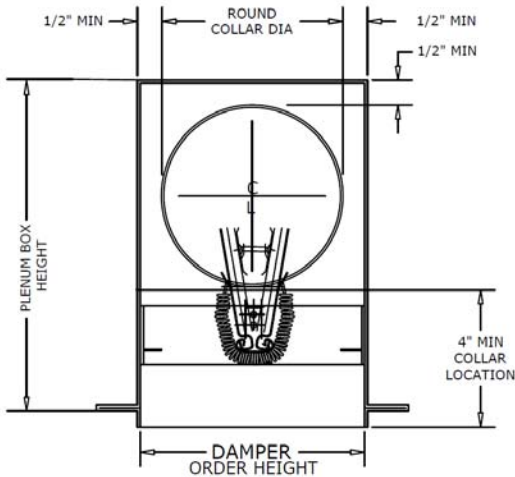

CEILING RADIATION DAMPER

- Rating: UL listed ceiling radiation damper UL-555C
Fusible Link: 165°F standard
Blades: 22 Ga. Galv. Steel with ceramic fiberglass cover
Frame: Roll formed 22 Ga. Galv. Steel

PLENUM BOX

- Outer Box: 26 Ga. Galv. Steel
Collar: Roll formed 26 Ga. Galv. Steel with roll formed 1/4" beading
Insulation: None provided
Round beaded collar provided to nominal dia order sizes (11/4").

NOTES:

- Available in stainless steel.
Manufactured with blades open as shown.
Minimum CRD50-EA-NI-BT register sizes not less than 6" on width and 4" on height.
Ceramic insulation is not required on dampers with areas less than 80 SQ/IN and is optional. Dampers above 80 SQ/IN will be provided with blade insulation.
Register/Grille supplied by other.

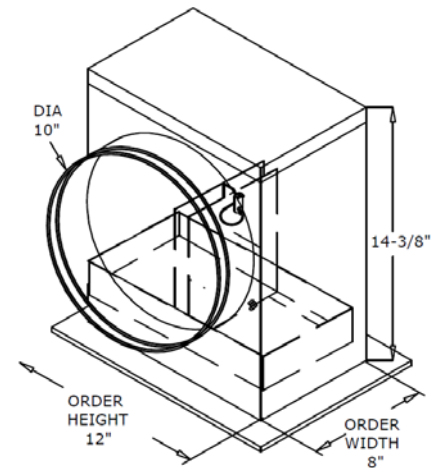

Table with 2 columns: Minimum Size (WxH) and Maximum Size (WxH). Rows show 6"x6"x3" (collar) and 24"x24"x22" (collar).