



DYNAMIC FIRE DAMPER



MODEL:
FD-111-PB

APPLICATION

The FD-111-PB is a multi-blade dynamic fire damper approved for use in walls, floors and partitions with fire resistance ratings less than 2 hours. This model carries a 1-1/2 hour UL fire damper label. UL 555 classifies dynamic rated fire dampers for use in HVAC

STANDARD CONSTRUCTION

- FRAME:** 16 ga. (1.5mm) Galvanized steel
Interlocking stacked hat section
Channel frame construction
- BLADES :** 16 ga. Galvanized 3 "V" formed
Parallel Blade
- BEARINGS:** Sintered Bronze, oil impregnated
- AXLES:** 1/2 Sq. zinc plated steel studs
- LINKAGE:** 0.12 x 0.50 zinc plated steel
concealed in the channel frame
- FINISH:** Mill galvanized
- BLADE SEALS:**None
- JAMB SEALS:** None
- JACKSHAFT:** 1/2" Dia. Zinc plated steel with
jackshaft connector coupling

RATINGS

- Fire rating: 1-1/2 Hours
Installations: Vertical/ Horizontal
Operation: Parallel blade

OPTIONS

- Sleeves: Rectangle, Round, Oval, and Specials
Optional Material: Stainless steel construction

UL CLASSIFIED: UL 555

Model FSD-111-PB meets the requirements for fire dampers, smoke dampers and combination fire smoke dampers established by:

- CSFM California State Fire Marshal
Fire Damper Listing (#3225-1417:102)**
- Leakage (Smoke) Damper Listing (#3230-1417:103)**
- New York City (MEA listing #215-99-E)**
- British Standard (BS – 476 Part 20)**
- Performance testing by AMCA International (AMCA STD 500)**
- HKFM Hong Kong fire Marshal Approval**

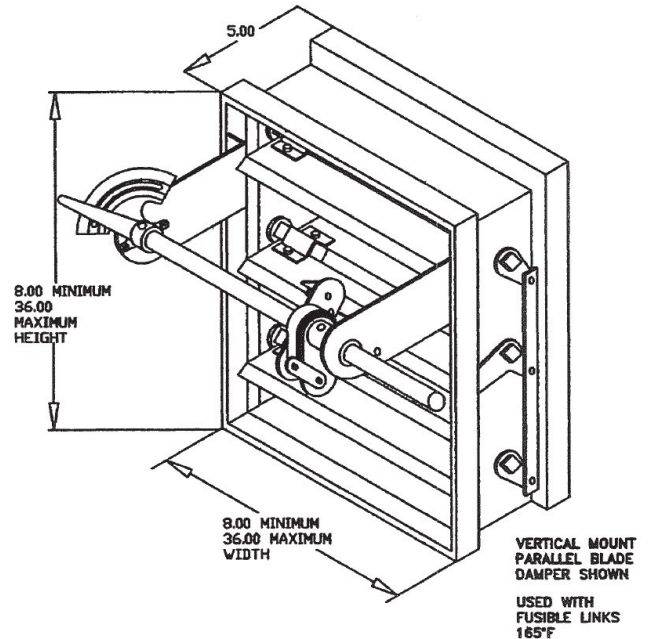

Single Section	
Minimum Size (WxH)	Maximum Size (WxH)
8"x8"	36"x36"

